

NEMA 4 Cabinet Cooler  
With Thermostat  
Part No. 4850



**Product Description**

NEMA 4 Dual Cabinet Cooler System, with Thermostat Control, 3400 Btu/hr, includes filter.

**Key Features**

Air Consumption:	1416L/m
Cooling Capacity:	3400Btu/hr
Sound Level:	84dBA
Material:	Aluminium

\*\*All measurements based on 6.9Bar air pressure with optional muffler installed\*\*

**What's In The Bag?**

2x Cabinet Cooler	4625
2x Cold Air Distribution Kit	4904
1x Thermostat	9017
1x 120 VAC Solenoid Valve	9034
1x Dual Cooler Hardware	4908
1x Air Filter	9032
1x Filter Mounting Bracket	900396

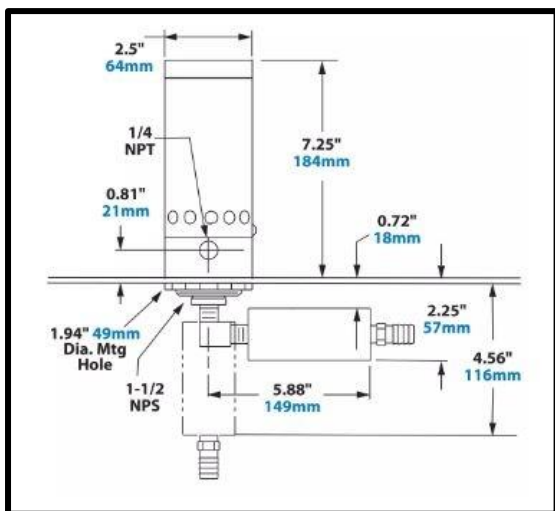

**Optional Extras**

Side Mount Kit	4907
----------------	------