

NEMA 12 Cabinet Cooler
With Thermostat
Part No. 4330



Product Description

NEMA 12 Cabinet Cooler System, 2000 Btu/hr., with 120VAC Thermostat Control, compressed air filter included

Key Features

Air Consumption: 850L/m
Cooling Capacity: 2000Btu/hr
Sound Level: 84dBA
Material: Aluminium

All measurements based on 6.9Bar air pressure with optional muffler installed

What's In The Bag?

Cabinet Cooler 4030
Cold Air Distribution Kit 4904
Thermostat 9017
120 VAC Solenoid Valve 9020
Air Filter 9004
Filter Mounting Bracket 900396

Optional Extras

Side Mount Kit 4910

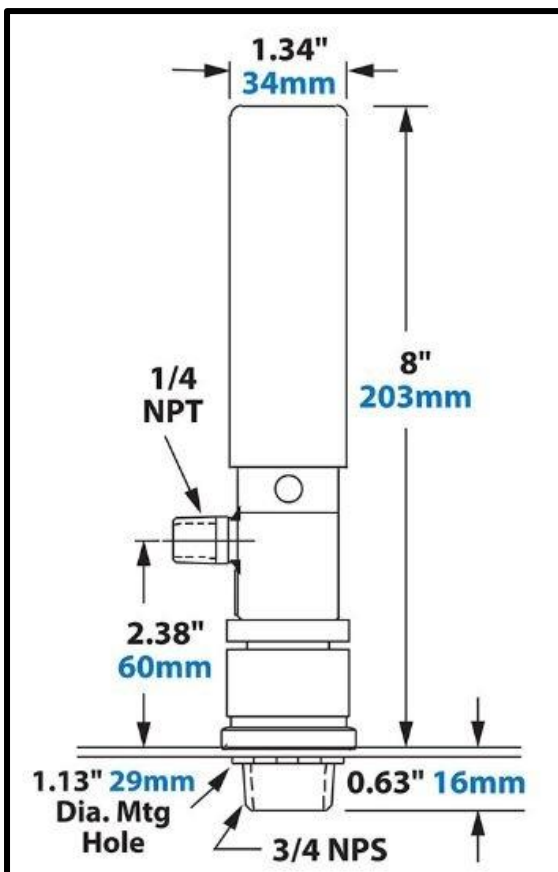

NEMA 12 Cabinet Cooler
With Thermostat
Part No. 4330



Supplied By
GH GoodHand UK
goodhanduk.co.uk
01908 221 151