

NEMA 4 Cabinet Cooler
With Thermostat
Part No. 4870



Product Description

NEMA 4 Dual Cabinet Cooler System, with 120 VAC Thermostat Control, 4800 Btu/hr, includes filter.

Key Features

Air Consumption:	1983L/m
Cooling Capacity:	4800Btu/hr
Sound Level:	84dBA
Material:	Aluminium

****All measurements based on 6.9Bar air pressure with optional muffler installed****

What's In The Bag?

1x Cabinet Cooler	4630
1x Cabinet Cooler	4640
2x Cold Air Distribution Kit	4904
1x Thermostat	9017
1x 120 VAC Solenoid Valve	9034
1x Dual Cooler Hardware	4908
1x Air Filter	9032
1x Filter Mounting Bracket	900396

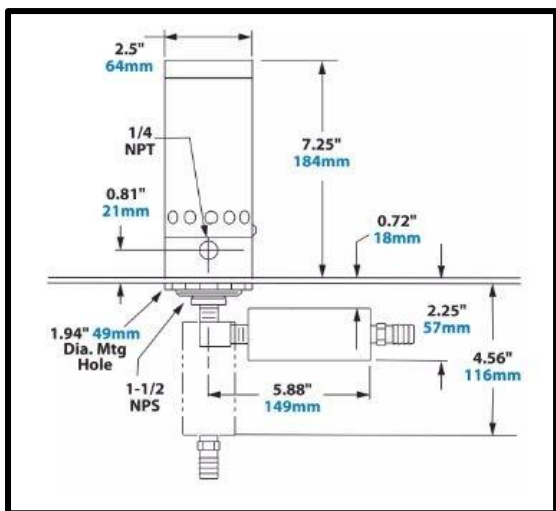

Optional Extras

Side Mount Kit	4907
----------------	------