

Indexing plungers without collar with extended indexing pin

Item description/product images

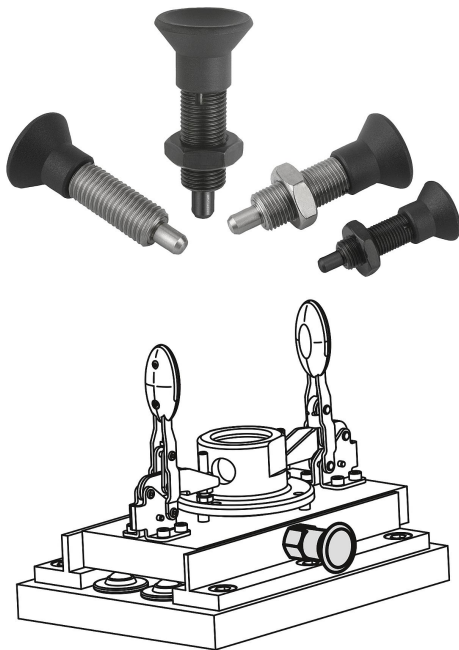

Description

Material:

Steel version

Indexing pin hardened:
grade 5.8.

Stainless steel version

Indexing pin hardened:
Threaded sleeve 1.4305.
Indexing pin 1.4034.

Indexing pin not hardened:

Threaded sleeve 1.4305.
Indexing pin 1.4305.

Mushroom knob black-grey thermoplastic.

Version:

Steel version:

Indexing pin hardened, ground, black oxidised.

Stainless steel version:

Indexing pin hardened, ground and bright.

Indexing pin not hardened, ground and bright.

Note:

Indexing plungers are used to prevent any change in locking position due to lateral forces. A new locking position can only be set after the pin has been manually disengaged.

A washer is available to aid by screwing in the indexing plungers. The washer slides beneath the mushroom knob so that the carrier pins engage in the slot.

On request:

Special versions.

Indexing plungers without collar with extended indexing pin

Drawings

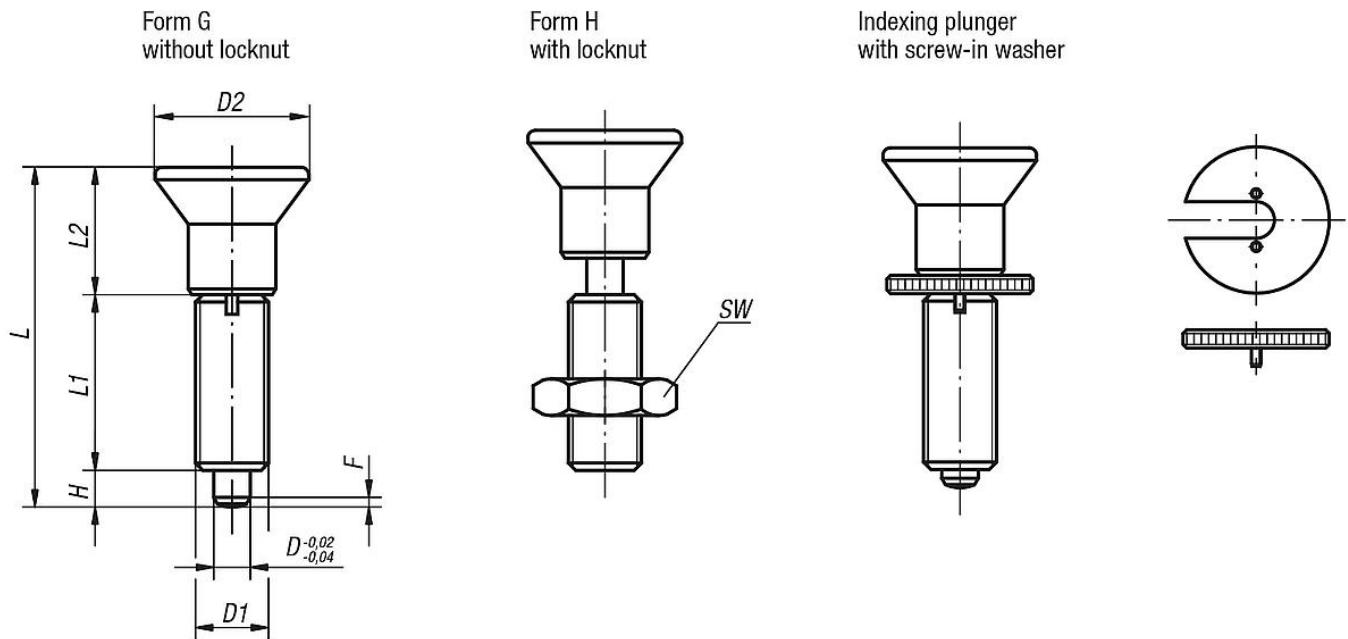

Overview of items

Indexing plungers without collar with extended indexing pin, steel, indexing pin hardened

Order No. Form G	Order No. Form H	D	D1	D2	L	L1	L2	H	SW	Fx30°	Spring force initial pressure F1 approx. N	Spring force final pressure F2 approx. N	Order No. screw-in washer
K0633.21903	K0633.22903	3	M6x0,75	14	33	17	11	5	- / 10	0,8	4,5	12	K0344.99
K0633.21004	K0633.22004	4	M8x1	18	40,5	21	13,5	6	- / 13	1	6	15	K0344.90
K0633.21105	K0633.22105	5	M10x1	21	46,5	24	14,5	8	- / 17	1,3	5	16	K0344.91
K0633.21206	K0633.22206	6	M12x1,5	25	54,7	28	17,7	9	- / 19	1,8	6	18	K0344.92
K0633.21308	K0633.22308	8	M16x1,5	33	72	36	24	12	- / 24	2,3	15	45	K0344.93
K0633.21410	K0633.22410	10	M20x1,5	33	79	40	24	15	- / 30	2,8	15	43	K0344.94
K0633.21412	K0633.22412	12	M20x1,5	33	84	42	24	18	- / 30	2,8	15	51	K0344.94
K0633.21516	K0633.22516	16	M24x2	40	104	50	30	24	- / 36	3,2	20	60	K0344.95

Indexing plungers without collar with extended indexing pin, stainless steel, indexing pin hardened

Order No. Form G	Order No. Form H	D	D1	D2	L	L1	L2	H	SW	Fx30°	Spring force initial pressure F1 approx. N	Spring force final pressure F2 approx. N	Order No. screw-in washer
K0633.201903	K0633.202903	3	M6x0,75	14	33	17	11	5	- / 10	0,8	4,5	12	K0344.99
K0633.201004	K0633.202004	4	M8x1	18	40,5	21	13,5	6	- / 13	1	6	15	K0344.90
K0633.201105	K0633.202105	5	M10x1	21	46,5	24	14,5	8	- / 17	1,3	5	16	K0344.91
K0633.201206	K0633.202206	6	M12x1,5	25	54,7	28	17,7	9	- / 19	1,8	6	18	K0344.92
K0633.201308	K0633.202308	8	M16x1,5	33	72	36	24	12	- / 24	2,3	15	45	K0344.93
K0633.201410	K0633.202410	10	M20x1,5	33	79	40	24	15	- / 30	2,8	15	43	K0344.94
K0633.201412	K0633.202412	12	M20x1,5	33	84	42	24	18	- / 30	2,8	15	51	K0344.94
K0633.201516	K0633.202516	16	M24x2	40	104	50	30	24	- / 36	3,2	20	60	K0344.95

Indexing plungers without collar with extended indexing pin, stainless steel, indexing pin not hardened

Order No. Form G	Order No. Form H	D	D1	D2	L	L1	L2	H	SW	Fx30°	Spring force initial pressure F1 approx. N	Spring force final pressure F2 approx. N	Order No. screw-in washer
K0633.211903	K0633.212903	3	M6x0,75	14	33	17	11	5	- / 10	0,8	4,5	12	K0344.99
K0633.211004	K0633.212004	4	M8x1	18	40,5	21	13,5	6	- / 13	1	6	15	K0344.90

Indexing plungers without collar with extended indexing pin

Overview of items

Order No. Form G	Order No. Form H	D	D1	D2	L	L1	L2	H	SW	Fx30°	Spring force initial pressure F1 approx. N	Spring force final pressure F2 approx. N	Order No. screw-in washer
K0633.211105	K0633.212105	5	M10x1	21	46,5	24	14,5	8	- / 17	1,3	5	16	K0344.91
K0633.211206	K0633.212206	6	M12x1,5	25	54,7	28	17,7	9	- / 19	1,8	6	18	K0344.92
K0633.211308	K0633.212308	8	M16x1,5	33	72	36	24	12	- / 24	2,3	15	45	K0344.93
K0633.211410	K0633.212410	10	M20x1,5	33	79	40	24	15	- / 30	2,8	15	43	K0344.94
K0633.211412	K0633.212412	12	M20x1,5	33	84	42	24	18	- / 30	2,8	15	51	K0344.94
K0633.211516	K0633.212516	16	M24x2	40	104	50	30	24	- / 36	3,2	20	60	K0344.95