

Super Air Amplifier
Part No. 120028

EXAIR[®]
Manufacturing Intelligent Compressed Air Products Since 1983



Product Description

8" Super Air Amplifier In Aluminium. 157mm Bore.
Amplification Ratio 25-1

Key Features

Air Consumption:	3396L/m
Amplification Ratio:	25:1
Output Air Volume:	84900L/m
Sound Level:	88dBA
Material:	Aluminium

****All measurements based on 5.5Bar****

What's In The Bag?

Air Amplifier	120024
---------------	--------

Optional Extras

Shim Set	120328
----------	--------

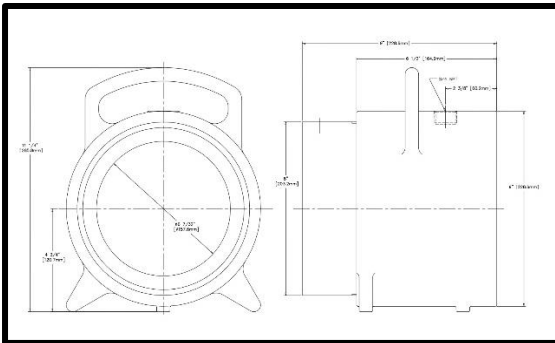

Supplied By
GH GoodHand UK
goodhanduk.co.uk
01908 221 151