

NEMA 4X Cabinet Cooler  
With Thermostat  
Part No. 4880SS



Product Description

NEMA 4X Dual Cabinet Cooler System, with 120 VAC Thermostat Control, 5600 Btu/hr, compressed air filter included

Key Features

Air Consumption: 2266L/m  
Cooling Capacity: 5600Btu/hr  
Sound Level: 85dBA  
Material: Stainless Steel

\*\*All measurements based on 6.9Bar air pressure with optional muffler installed\*\*

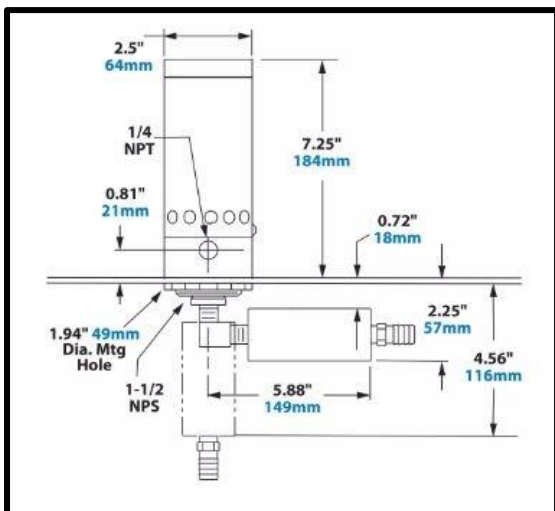

What's In The Bag?

- 2x Cabinet Cooler 4640SS
- 2x Cold Air Distribution Kit 4904
- 1x Thermostat 9017
- 1x 120 VAC Solenoid Valve 9034
- 1x Dual Cooler Hardware 4908
- 1x Air Filter 9032
- 1x Filter Mounting Bracket 900396

Optional Extras

- Side Mount Kit 4907