

Indexing plungers

Item description/product images

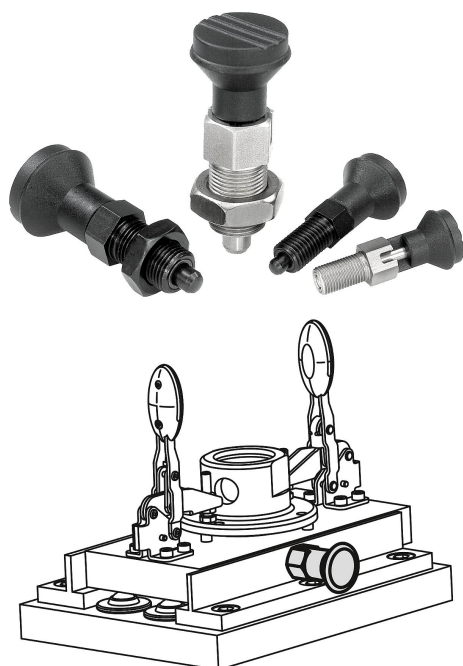

Description

Material:

Steel version

Indexing pin hardened:
grade 5.8.

Stainless steel version

Indexing pin hardened:
Threaded sleeve 1.4305.
Indexing pin 1.4034.

Indexing pin not hardened:

Threaded sleeve 1.4305.
Indexing pin 1.4305.

Mushroom knob black-grey thermoplastic.

Version:

Steel version:

Indexing pin hardened, ground, black oxidised.

Stainless steel version:

Indexing pin hardened, ground and bright.

Indexing pin not hardened, ground and bright.

Note:

Indexing plungers are used to prevent any change in locking position due to lateral forces. A new locking position can only be set after the pin has been manually disengaged. Form C or D is recommended for applications in which the pin is disengaged over extended periods and should be prevented from springing back.

On request:

Special versions.

Indexing plungers

Drawings

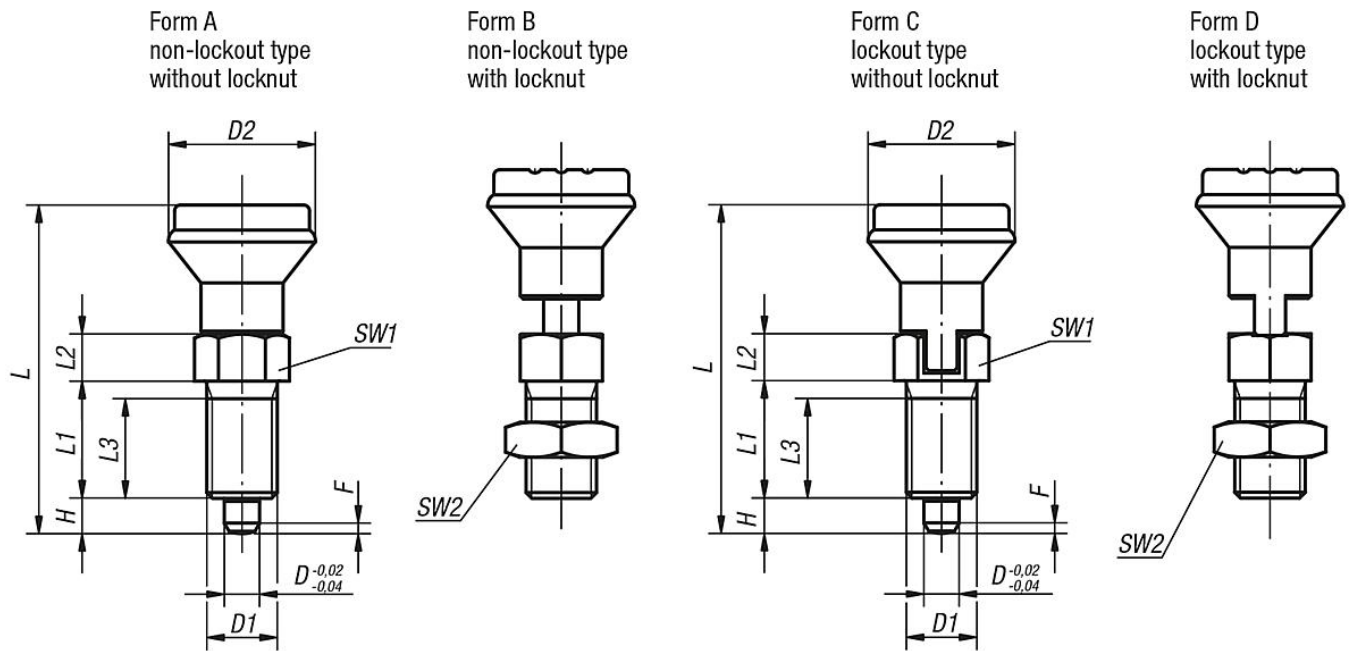

Overview of items

Indexing plungers, steel, indexing pin hardened

Order No. Form A	Order No. Form B	Order No. Form C	Order No. Form D	D	D1	D2	L	L1	L2	L3	H	SW1	SW2	Fx30°	Spring force initial pressure F1 approx. N	Spring force final pressure F2 approx. N
K0339.1105	K0339.2105	K0339.3105	K0339.4105	5	M10x1	21	47	17	7	15	5	13	-/17-/17	1,3	5	12
K0339.1206	K0339.2206	K0339.3206	K0339.4206	6	M12x1,5	25	56	20	8	17	6	14	-/19-/19	1,8	6	14
K0339.1308	K0339.2308	K0339.3308	K0339.4308	8	M16x1,5	33	74	26	10	23	8	19	-/24-/24	2,3	15	35
K0339.1410	K0339.2410	K0339.3410	K0339.4410	10	M20x1,5	33	80	28	12	25	10	22	-/30-/30	2,8	15	34

Indexing plungers, stainless steel, indexing pin hardened

Order No. Form A	Order No. Form B	Order No. Form C	Order No. Form D	D	D1	D2	L	L1	L2	L3	H	SW1	SW2	Fx30°	Spring force initial pressure F1 approx. N	Spring force final pressure F2 approx. N
K0339.01105	K0339.02105	K0339.03105	K0339.04105	5	M10x1	21	47	17	7	15	5	13	-/17-/17	1,3	5	12
K0339.01206	K0339.02206	K0339.03206	K0339.04206	6	M12x1,5	25	56	20	8	17	6	14	-/19-/19	1,8	6	14
K0339.01308	K0339.02308	K0339.03308	K0339.04308	8	M16x1,5	33	74	26	10	23	8	19	-/24-/24	2,3	15	35
K0339.01410	K0339.02410	K0339.03410	K0339.04410	10	M20x1,5	33	80	28	12	25	10	22	-/30-/30	2,8	15	34

Indexing plungers, stainless steel, indexing pin not hardened

Order No. Form A	Order No. Form B	Order No. Form C	Order No. Form D	D	D1	D2	L	L1	L2	L3	H	SW1	SW2	Fx30°	Spring force initial pressure F1 approx. N	Spring force final pressure F2 approx. N
K0339.11105	K0339.12105	K0339.13105	K0339.14105	5	M10x1	21	47	17	7	15	5	13	-/17-/17	1,3	5	12
K0339.11206	K0339.12206	K0339.13206	K0339.14206	6	M12x1,5	25	56	20	8	17	6	14	-/19-/19	1,8	6	14
K0339.11308	K0339.12308	K0339.13308	K0339.14308	8	M16x1,5	33	74	26	10	23	8	19	-/24-/24	2,3	15	35
K0339.11410	K0339.12410	K0339.13410	K0339.14410	10	M20x1,5	33	80	28	12	25	10	22	-/30-/30	2,8	15	34