

NEMA 12 Cabinet Cooler  
With Thermostat  
Part No. 4304



**Product Description**

NEMA 12 Cabinet Cooler System, 275 Btu/hr., with 120VAC Thermostat Control, compressed air filter included

**Key Features**

Air Consumption:	57L/m
Cooling Capacity:	275Btu/hr
Sound Level:	59dBA
Material:	Aluminium

**\*\*All measurements based on 6.9Bar air pressure with optional muffler installed\*\***

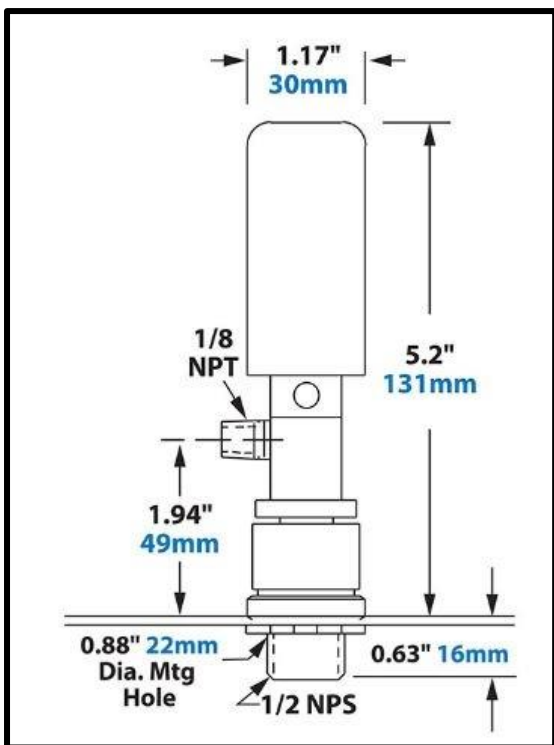

**What's In The Bag?**

Cabinet Cooler	4625SS
Cold Air Distribution Kit	4905
Thermostat	9017
120 VAC Solenoid Valve	9020
Air Filer	9004
Filter Mounting Bracket	900396

**Optional Extras**

Side Mount Kit	4909
----------------	------