

NEMA 12 Cabinet Cooler  
With Thermostat  
Part No. 4315



**Product Description**

NEMA 12 Cabinet Cooler System, 1000 Btu/hr., with 120VAC Thermostat Control, compressed air filter included

**Key Features**

Air Consumption:	425L/m
Cooling Capacity:	1000Btu/hr
Sound Level:	81dBA
Material:	Aluminium

\*\*All measurements based on 6.9Bar air pressure with optional muffler installed\*\*

**What's In The Bag?**

Cabinet Cooler	4015
Cold Air Distribution Kit	4904
Thermostat	9017
120 VAC Solenoid Valve	9020
Air Filter	9004
Filter Mounting Bracket	900396

**Optional Extras**

Side Mount Kit	4910
----------------	------

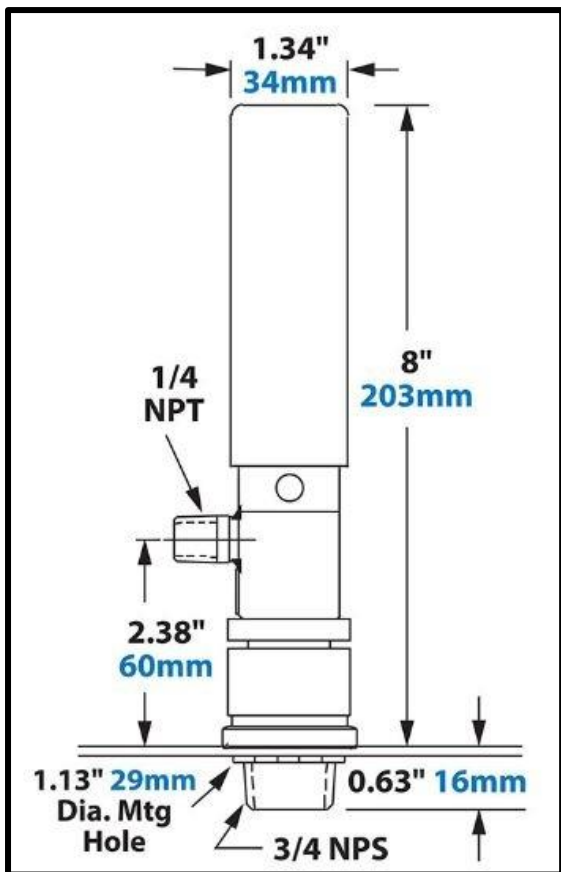

Supplied By



[goodhanduk.co.uk](http://goodhanduk.co.uk)

01908 221 151

NEMA 12 Cabinet Cooler  
With Thermostat  
Part No. 4315



Supplied By  
**GH GoodHand UK**  
[goodhanduk.co.uk](http://goodhanduk.co.uk)  
01908 221 151