

NEMA 12 Cabinet Cooler
With Thermostat
Part No. 4325



Product Description

NEMA 12 Cabinet Cooler System, 1700 Btu/hr., with 120VAC Thermostat Control, compressed air filter included

Key Features

Air Consumption:	708L/m
Cooling Capacity:	1700Btu/hr
Sound Level:	81dBA
Material:	Aluminium

All measurements based on 6.9Bar air pressure with optional muffler installed

What's In The Bag?

Cabinet Cooler	4025
Cold Air Distribution Kit	4904
Thermostat	9017
120 VAC Solenoid Valve	9020
Air Filter	9004
Filter Mounting Bracket	900396

Optional Extras

Side Mount Kit	4910
----------------	------

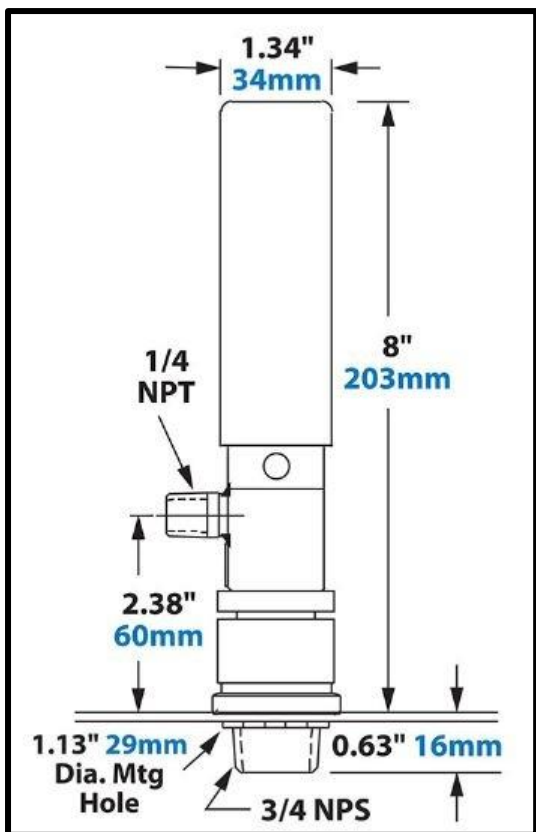

Supplied By

GH GoodHand UK

goodhanduk.co.uk

01908 221 151