

## Indexing plungers without collar

### Item description/product images

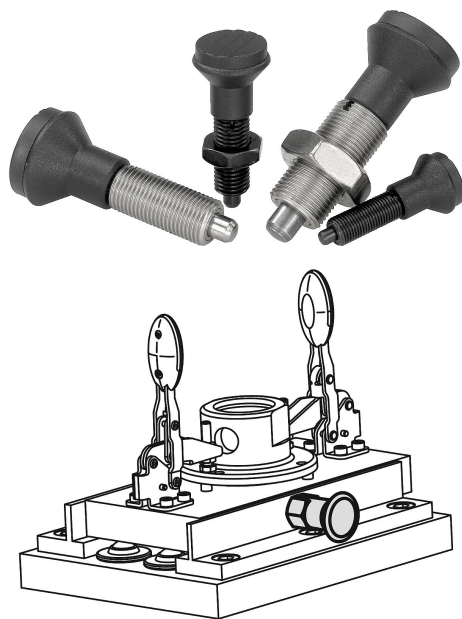

### Description

#### Material:

Steel version  
Indexing pin hardened:  
grade 5.8.

Stainless steel version  
Indexing pin hardened:  
Threaded sleeve 1.4305.  
Indexing pin 1.4034.

Indexing pin not hardened:  
Threaded sleeve 1.4305.  
Indexing pin 1.4305.

Mushroom knob black-grey thermoplastic.

#### Version:

Steel version:  
Indexing pin hardened, ground, black oxidised.

Stainless steel version:  
Indexing pin hardened, ground and bright.  
Indexing pin not hardened, ground and bright.

#### Note:

Indexing plungers are used to prevent any change in locking position due to lateral forces. A new locking position can only be set after the pin has been manually disengaged.

A screw-in washer can be supplied to help screw in the indexing plungers. The washer is slid beneath the disengaged mushroom knob so that the carrier pins engage in the slot.

#### On request:

Special versions.

# Indexing plungers without collar

## Drawings

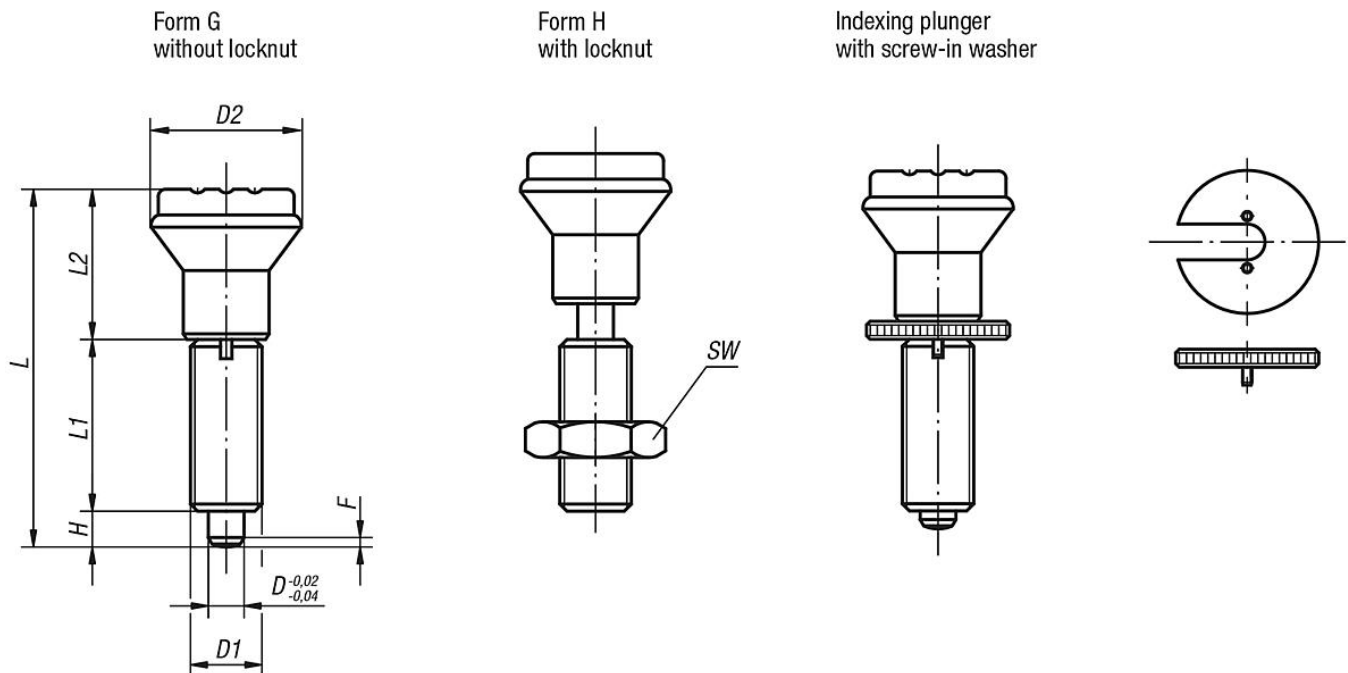

## Overview of items

### Indexing plungers without collar, steel, indexing pin hardened

Order No. Form G	Order No. Form H	D	D1	D2	L	L1	L2	H	SW	Fx30°	Spring force initial pressure F1 approx. N	Spring force final pressure F2 approx. N	Order No. screw-in washer
K0344.1105	K0344.2105	5	M10x1	21	47	24	18	5	-/17	1,3	5	12	K0344.91
K0344.1206	K0344.2206	6	M12x1,5	25	56	28	22	6	-/19	1,8	6	14	K0344.92
K0344.1308	K0344.2308	8	M16x1,5	33	74	36	30	8	-/24	2,3	15	35	K0344.93
K0344.1410	K0344.2410	10	M20x1,5	33	80	40	30	10	-/30	2,8	15	34	K0344.94

### Indexing plungers without collar, stainless steel, indexing pin hardened

Order No. Form G	Order No. Form H	D	D1	D2	L	L1	L2	H	SW	Fx30°	Spring force initial pressure F1 approx. N	Spring force final pressure F2 approx. N	Order No. screw-in washer
K0344.01105	K0344.02105	5	M10x1	21	47	24	18	5	-/17	1,3	5	12	K0344.91
K0344.01206	K0344.02206	6	M12x1,5	25	56	28	22	6	-/19	1,8	6	14	K0344.92
K0344.01308	K0344.02308	8	M16x1,5	33	74	36	30	8	-/24	2,3	15	35	K0344.93
K0344.01410	K0344.02410	10	M20x1,5	33	80	40	30	10	-/30	2,8	15	34	K0344.94

### Indexing plungers without collar, stainless steel, indexing pin not hardened

Order No. Form G	Order No. Form H	D	D1	D2	L	L1	L2	H	SW	Fx30°	Spring force initial pressure F1 approx. N	Spring force final pressure F2 approx. N	Order No. screw-in washer
K0344.11105	K0344.12105	5	M10x1	21	47	24	18	5	-/17	1,3	5	12	K0344.91
K0344.11206	K0344.12206	6	M12x1,5	25	56	28	22	6	-/19	1,8	6	14	K0344.92
K0344.11308	K0344.12308	8	M16x1,5	33	74	36	30	8	-/24	2,3	15	35	K0344.93
K0344.11410	K0344.12410	10	M20x1,5	33	80	40	30	10	-/30	2,8	15	34	K0344.94

