

# Handwheels disc without grip

## Item description/product images



### Description

#### Material:

Black thermoset PF 31.

Hub nickel-plated steel or bright 1.4305 stainless steel.

#### Version:

High-gloss polished.

#### On request:

Other reamed hole sizes.

#### Drawing reference:

Form D: pilot hole

Form E: reamed hole

## Drawings

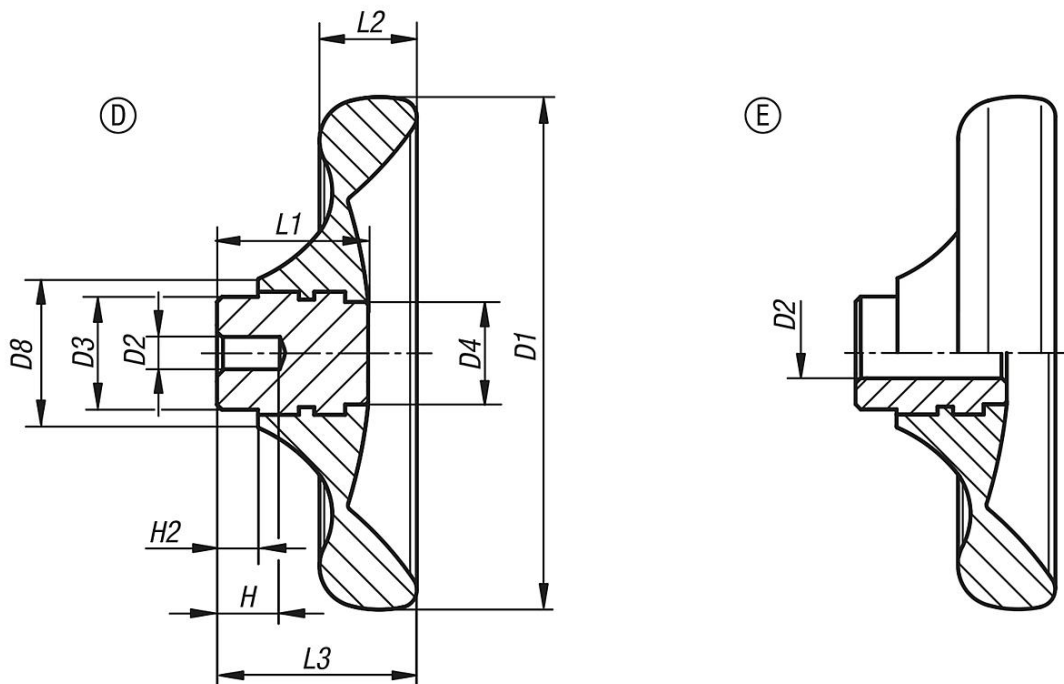

## Overview of items

### Handwheels disc, without grip, bush steel

Order No.	Version 1	Form	D1	D2	D3	D4	D8	H	H2	L1	L2	L3
K0165.0100X06	pre-drilled	D	100	6	22	20	29	12	8	29,5	19	39
K0165.0125X08	pre-drilled	D	125	8	26	21	34	15	8	34	24	46
K0165.0140X08	pre-drilled	D	140	8	30	25	39	16	8	38,5	27	52
K0165.0160X10	pre-drilled	D	160	10	33	30	43	20	8	41,3	30,1	57
K0165.1100X10	reamed hole	E	100	10H8	22	20	29	-	8	29,5	19	39
K0165.1125X12	reamed hole	E	125	12H8	26	21	34	-	8	34	24	46
K0165.1140X14	reamed hole	E	140	14H8	30	25	39	-	8	38,5	27	52
K0165.1160X16	reamed hole	E	160	16H8	33	30	43	-	8	41,3	30,1	57
K0165.1160X18	reamed hole	E	160	18H8	33	30	43	-	8	41,3	30,1	57
K0165.2100X06	pre-drilled	D	100	6	22	20	29	12	8	29,5	19	39

## Handwheels disc without grip

### Overview of items

Order No.	Version 1	Form	D1	D2	D3	D4	D8	H	H2	L1	L2	L3
K0165.2125X08	pre-drilled	D	125	8	26	21	34	15	8	34	24	46
K0165.2140X08	pre-drilled	D	140	8	30	25	39	16	8	38,5	27	52
K0165.2160X10	pre-drilled	D	160	10	33	30	43	20	8	41,3	30,1	57
K0165.3100X10	reamed hole	E	100	10H7	22	20	29	-	8	29,5	19	39
K0165.3125X12	reamed hole	E	125	12H7	26	21	34	-	8	34	24	46
K0165.3140X14	reamed hole	E	140	14H7	30	25	39	-	8	38,5	27	52
K0165.3160X16	reamed hole	E	160	16H7	33	30	43	-	8	41,3	30,1	57
K0165.3160X18	reamed hole	E	160	18H7	33	30	43	-	8	41,3	30,1	57